

# Photovoltaic Module Installation Manual of TONGWEI CO., LTD



This manual applies to Module types:

	With ½ cut of 182 mono c-Si cell	With ½ cut of 210*210 mono c-Si cell	With ½ cut of 182*210 mono c-Si cell
<b>Monofacial Module</b>	TWMPD-78HS	TWMPF-66HS	TWMNH-66HS
	TWMPD-72HS	TWMPF-60HS	
	TWMPD-66HS	TWMPF-54HS	
	TWMPD-60HS	TWMPF-55HS	
	TWMPD-54HS	TWMPF-50HS	
	TWMPD-54HB	TWMNF-60HS	
	TWMND-78HS	TWMNF-66HS	
	TWMND-72HS		
	TWMND-66HS		
	TWMND-60HS		
	TWMND-54HS		
	TWMND-54HB		
<b>Bifacial Module</b>	TWMPD-78HD	TWMPF-66HD	TWMNH-66HD
	TWMPD-72HD	TWMPF-60HD	TWMNH-48HD
	TWMPD-66HD	TWMPF-55HD	TWMNH-48HC
	TWMPD-60HD	TWMPF-54HD	
	TWMND-78HD	TWMPF-50HD	
	TWMND-72HD	TWMHF-66HD	
	TWMND-66HD	TWMHF-60HD	
	TWMND-60HD	TWMNF-60HD	
	TWMNF-66HD		

# Contents

<b>1</b>	<b>01</b>	<b>Manual Description</b>	
<b>1</b>	<b>02</b>	<b>Disclaimer</b>	
<b>1</b>	<b>03</b>	<b>Module Information</b>	
<b>2</b>	<b>04</b>	<b>Module Safety</b>	
	4.1	General Rules	
	4.2	Electrical Performance Safety	
	4.3	Transportation and Handling Safety	
	4.4	Installation Safety	
	4.5	Fire Safety	
<b>4</b>	<b>05</b>	<b>Unloading, Transshipment, Storage, Unpacking</b>	
	5.1	Packaging	
	5.2	Unloading	
	5.3	Transshipment	
	5.4	Storage	
	5.5	Unpacking	
<b>8</b>	<b>06</b>	<b>Installation Conditions</b>	
	6.1	Installation Environment	
	6.2	Inclination Selection	
<b>9</b>	<b>07</b>	<b>MECHANICAL INSTALLATION</b>	
	7.1	General Rules	
	7.2	Installation method	
<b>15</b>	<b>08</b>	<b>Electrical Installation</b>	
	8.1	General Installation	
	8.2	Module Layout And Wiring	
	8.3	Cables and Connectors	
	8.4	Grounding	
<b>18</b>	<b>09</b>	<b>Module Maintenance</b>	
	9.1	Module Appearance Inspection	
	9.2	Inspection Of Connector and Cable	
	9.3	Module Cleaning	



## 01 MANUAL DESCRIPTION

- This manual applies only to the solar Module (The following will be referred to as ‘Module’) of TONGWEI Co., Ltd (The following will be referred to as ‘TW’). This manual contains information on the installation methods, operation safety and maintenance of TW Solar Module. Please read the following installation instructions carefully before installing and maintaining the Module.
- The Module must be installed by a professional who is familiar with the mechanical and electrical requirements during installation. Installers must strictly adhere to the manual instructions, as well as comply with local laws, regulations, and requirements from authorized agencies.
- Please store this manual in a secure location for future reference during maintenance, servicing, and when selling or disposing of the components.

## 02 DISCLAIMER

- This installation manual does not constitute any warranty, whether expressed or implied. Failure to operate the Module in accordance with the requirements listed in this manual will result in the nullification of the limited warranty provided to the customer. TW is not responsible for any losses incurred from the installation, operation, use, or maintenance of Modules that do not comply with the guidance in this manual, including personal injuries, Modules malfunctions or damages, or any other expenses.
- No customer shall obtain a patent or patent license through the use of this Module installation manual (express or implied). Liability related to infringement of third-party patents or other rights arising from the use of the Module and this manual is not the responsibility of TW.
- TW reserves the right to change this manual without prior notice.

## 03 MODULE INFORMATION

- There are 3 types of labels affixed to each Module, providing information as follows:
  - ◇ Nameplate: Maximum power, open circuit voltage, short circuit current, maximum power point voltage, maximum power point current under standard test conditions, maximum system voltage, certification mark and other information.
  - ◇ Serial Number: Each Module has a unique serial number. This serial number is printed on the barcode, which is put into the Module before lamination and cannot be torn or smeared after lamination. In addition, an identical serial number can be found above or next to the Module nameplate.
  - ◇ Current Grading Labeling: The Module are graded according to the rated current and are identified and differentiated on the Module with labels located on the Module frame barcode and the Module nameplate.

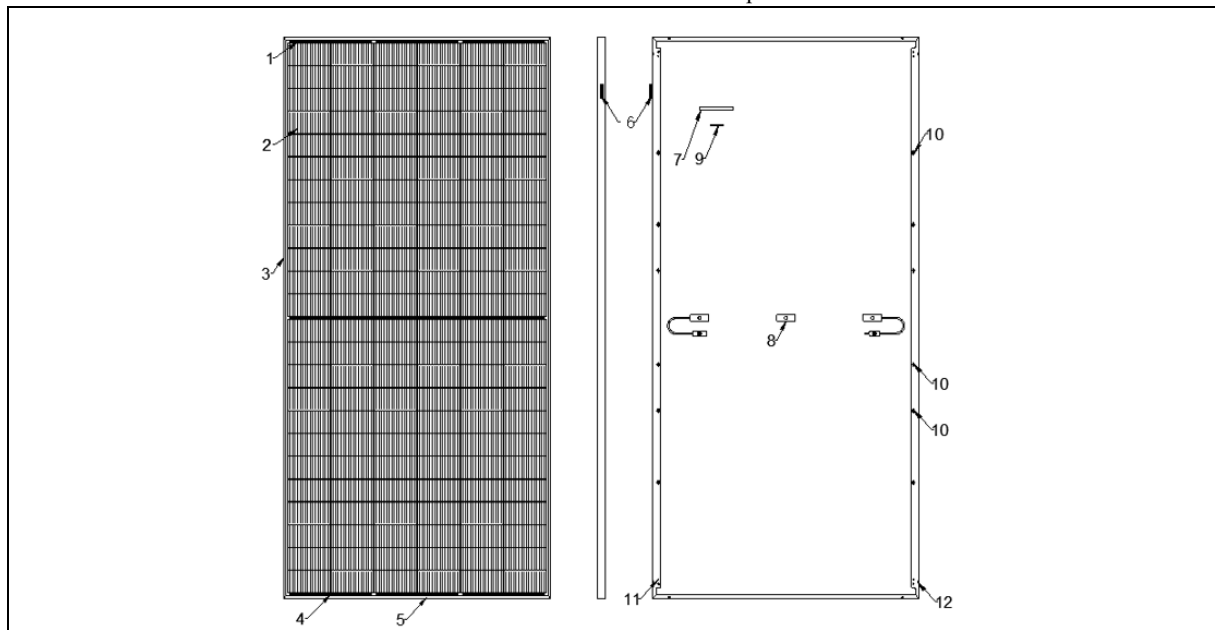
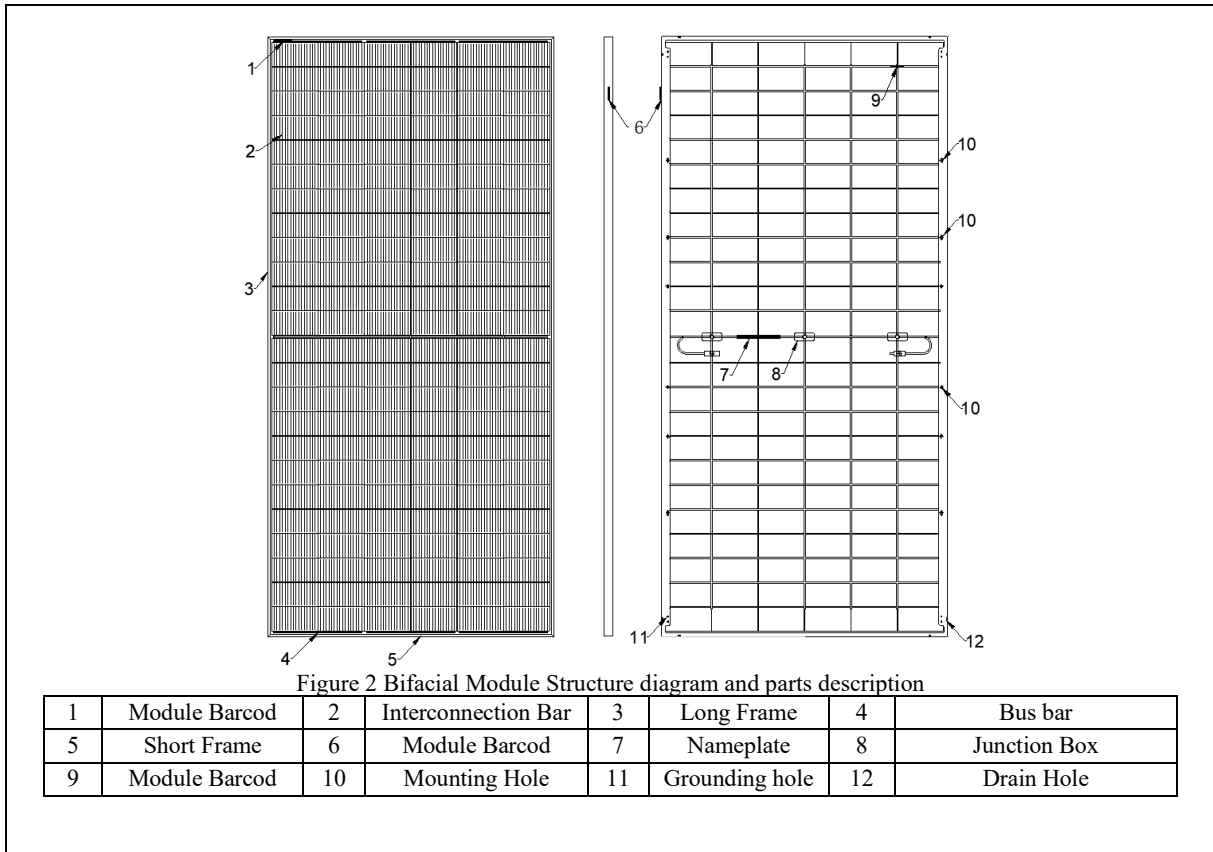

Figure 1 Monofacial Module Structure diagram and parts description

1	Module Barcod	2	Interconnection Bar	3	Long Frame	4	Bus bar
5	Short Frame	6	Module Barcod	7	Nameplate	8	Junction Box
9	Module Barcod	10	Mounting Hole	11	Grounding hole	12	Drain Hole



## 04 MODULE SAFETY

### 4.1 General Rules

- TW Modules are designed in accordance with the International Electrotechnical Commission (IEC) standards IEC 61215 and IEC 61730, with an application class of Class A. The Modules can be used in systems with a DC voltage greater than 50V or a power output exceeding 240W, which may be exposed to the public. The safety class of the Modules is Class II, and the fire rating is Class C.
- No matter whether the Module are connected to the system or not, appropriate protective measures should be used when touching the Module, such as: insulated tools, safety helmets, insulated gloves, safety belts and safety insulated shoes. When performing operations like installation, grounding, wiring, cleaning, etc., it is essential to use proper electrical safety protective tools. Avoid direct contact with the Module, which may cause electric shock or cuts.
- For your safety, it is strictly prohibited to install or handle the Module in hazardous environments, including but not limited to strong winds or gusts, wet or sandy roofs.
- Do not attempt to disassemble the Module or remove the Module nameplate or parts on the Module. Do not paint or apply any other adhesive to the surface of the Module. Avoid damaging the Module backsheet and do not scratch or scuff the Module backsheet.
- In addition to grounding connections, drilling holes in the Module frame is prohibited, as this may reduce the frame loading capacity and lead to frame corrosion.
- Do not scratch the anodic oxide layer on the surface of the aluminum alloy frame. Scratches may cause the frame to corrode affecting the load capacity of the frame.
- It is prohibited to repair Module with damaged glass or backsheet by yourself, and scarp Module shall be recycled and disposed of by qualified organizations.
- Reference/Statement that in Australia installations should be in accordance to AS/NZS 3000 and AS/NZS 5033.



- Meaning of crossed-out wheeled dustbin: Do not dispose of electrical appliances as unsorted municipal waste, use separate collection facilities. Contact your local government for information regarding the collection systems available.
- If electrical appliances are disposed of in landfills or dumps, hazardous substances can leak into the groundwater and get into the food chain, damaging your health and well-being. When replacing old appliances with new ones, the retailer is legally obligated to take back your old appliance for disposals at least free of charge.

## 4.2 Electrical Performance Safety

- PV Module can produce DC current under sunlight. So appropriate protective measures (insulated gloves, insulated shoes, etc.) should be taken to prevent personnel from direct contact with 30V or higher direct current voltage. 30V or higher direct current voltage can be potentially lethal.
- In case of no connected load or external circuits, Module can still produce voltage. Please use insulation tools and wear rubber gloves when operating Module in the sunlight.
- PV Module do not have switches, operating of PV Module can only be stopped when they are kept from sunlight or covered by hard board or UV-proof materials or when the angle of the Module facing sun are placed on smooth and flat surfaces.
- To avoid electric arc and electric shock hazards, please do not break down electric connection in loaded conditions. Incorrect connections will also lead to electric arc or shock. Keep connectors dry and clean and make sure that they are in good operating conditions. Do not insert other metals into the connectors or carry out electric connection by whatever means.
- Snow, water or other reflective medium in surrounding environment that intensify light re-reflection will increase output current and power. And Module voltage and power will increase under low temperature condition.
- If Module glass or other sealing materials are damaged, please wear personal protective equipment and then isolate Module from the circuit.
- Work must only be carried out in dry conditions using dry tools. Do not operate when Module are wet unless you wear personal protective equipment. Please follow the cleaning requirements in this manual when cleaning Module.
- Installation must be carried out under the guidance of a qualified electrician.
- No matter what weather condition is, personnel entering the power station shall wear safety helmet, insulating gloves and insulating shoes correctly, taking-safety protection measures.

## 4.3 Transportation And Handling Safety

- Do not open the box until the Module has arrived at the installation site. Please make sure to use the correct and proper way to transport the Module and protect the package from damage, otherwise it may cause damage to the Module.
- When stacking the Module, please do not exceed the maximum number of layers limit as printed on the packing box. Before opening the Module, please put the packing box in a ventilated, dry and rainproof site and environment.
- It is forbidden to climb, stand, walk or jump on the packing box and the Module, which will risk damaging the Module and causing personal injury.
- During all handling processes, make ensure that the Modules are not subjected to significant vibrations, dropped onto the ground, or impacted by falling objects, as this may cause damage to the Modules or the cells inside. Do not allow children and unauthorized person to handle the Module. Improper handling and placement may result in broken glass or loss of electrical performance and loss of the Module's usefulness.
- The Module should be handled and placed gently during handling and installation. Under no circumstances is it permitted to pick up the entire Module by grasping the junction box or wires.
- Two or more people must hold the edges of the Module with both hands.

## 4.4 Installation Safety

- The installation of Modules should comply with the laws and regulations specified by the relevant local and national authorities of the installation site, if necessary, the required documents such as building permits should be obtained first.
- It is recommended that the Module be installed by professionals with experience in PV system installation, and that protective measures such as protective headgear, insulated gloves and rubber insulated shoes be worn during installation.
- Do not wear metal jewelry when installing or servicing the PV system, as this may poke through the Module and cause a risk of electric shock.
- Before installation, ensure that all Modules and electrical connectors are clean and dry.
- It is prohibited to install or handle the Module in rain, snow or windy conditions. If Modules are installed or handled after rain or on dewy mornings, proper protection is required to avoid moisture penetration into the connectors.
- Once the Module is removed from the box it needs to be installed and connected to the inverter in a timely manner, or if not, the connectors need to be well protected (e.g., by adding rubber connector caps, etc.).
- It is prohibited to drop any tools or other objects on the front or back of the Module, as this may cause visible or invisible damage to the Module; when placing a piece of the Module on a flat surface, it must be handled carefully, especially in corner areas.
- Before installation, carefully inspect the Module before installation for abnormalities such as burst glass, cracked cells, scratches on the backsheet, deformation of the mounting holes, dislodged junction boxes or missing box covers, dislodged or missing nameplates, broken cables and connectors, etc.
- Installation or use of damaged Module is prohibited. If the surface glass is damaged or worn, direct contact with the surface of the Module may result in electric shock.
- When using scaffold for installation, ensure that the scaffolding is in a stable position or has anti-tipping measures, and the installer should wear a safety belt in accordance with the requirements of the local building code. It is recommended that you do

not stand on the low side of the tilted surface of the Module when installing it, so as to prevent the Module from slipping off and causing injury or death.

- When the Modules are installed on the roof, the overall fire rating of the final structure needs to be considered. Overall maintenance at a later stage also needs to be considered. The roof on which the PV system is to be installed must have been assessed by a construction expert or engineer, with a formal and complete structural analysis and be proven to be able to withstand the additional stresses of the system mounting, including the weight of the Module themselves.
- For your safety, please do not work on the roof without safety precautions, which include but are not limited to fall protection, ladders or stairs and personal protective equipment.

## 4.5 Fire Safety

- Before installing the Module, please consult the local laws and regulations and comply with their requirements regarding the fire resistance of the building.
- Roofs are constructed and installed differently to affect the fire safety of the building. If not properly installed, a fire may result.
- The minimum distance between the Module frame and the roof surface is 10 cm to facilitate ventilation and heat dissipation of the Module.
- Please use appropriate Module accessories such as fuses, circuit breakers, and grounding connectors as required by local codes.
- It is prohibited to store, install or use the Module in a place where flammable gases are likely to be generated or gathered.

## 05 UNLOADING, TRANSSHIPMENT, STORAGE, UNPACKING

- The unloading, transshipment, storage, and unpacking of the Module must comply with this manual and the laws and regulations of the project location and other requirements. TW shall not be liable for any damages arising from non-compliance with this manual, including personal injuries, malfunctions or damages to the Module, or any other costs incurred.

### 5.1 Packaging

- TW Module are available in horizontal and vertical packaging according to different product types, and the horizontal and vertical packaging styles are as follows:

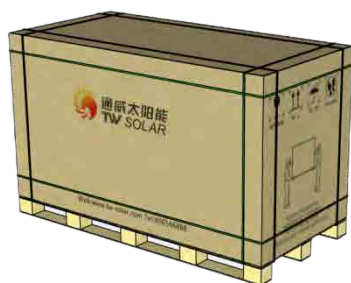

Figure 3 Horizontal Packaging



Figure 4 Vertical packaging

- Box labelling instructions:



1. DO NOT expose the module to rain or moisture.



2. The Modules in the carton box are fragile. Handle with care.



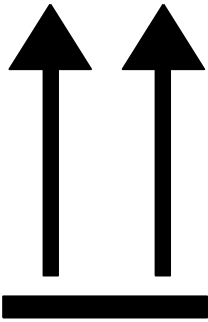

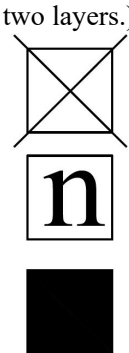
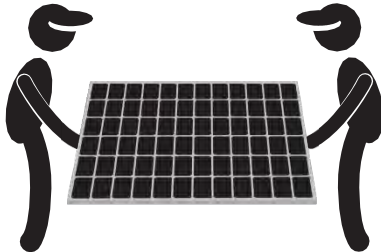
<p>3. The package shall never be upside down during the transportation.</p> 	<p>4. It is prohibited to stamp on the packing box and module.</p> 
<p>5. During the stacking of the Modules, the outer packing box can be stacked not exceed the maximum layer allowed. (n=2 means it is allowed to stack for at most two layers.)</p> 	<p>6. One module shall be handled by two people together.</p> 

## 5.2 Unloading

- After the delivery of the Modules, please check the overall status of the outer package in time, and check whether the model and quantity of the Modules on the outer package are consistent with the delivery note. If the package is damaged, deformed, or skewed, please contact TW's customer service or logistics personnel immediately.
- The unloading of Modules should be carried out in a flat, solid, open and clear field, which is convenient for observation and operation by crane and forklift operators.

### 5.2.1 Crane Unloading

- When unloading the Module by crane, please choose the rope with sufficient tension according to the weight and size of the Module, and the rope should be sufficiently long nylon sling, and the use of steel wire rope is not allowed.
- The sling should be supported on the top of the packing box by a wooden board of the same width as the outer box of the Module or other special work tools to prevent the sling from squeezing the Module inside the packing box. Before lifting, it should be confirmed whether the pallet and carton are damaged, whether the sling is strong and firm, whether the length of the sling on both sides of the packing box is evenly distributed, and whether the sling should not be too close to the middle and the edge of the box. Please adjust the position of the sling to keep the centre of gravity of the Module stable.
- When lifting the Modules, please adjust the position of the sling to keep the centre of gravity of the Module stable. You should keep the box balanced to avoid the box tilted which cause the sling affecting the safety of the Modules.
- When unloading the cargo need to have a professional person to command. Crane operator and commanders must hold professional operating documents. Unloading the cargo should try to maintain smoothly, avoid touching, falling Module box, when lifting close to the ground. Two people respectively upright the carton on different sides and gently place it on a relatively flat position.



Figure 6 Schematic diagram of Module lifting

- It is strictly prohibited to lift the Module under the meteorological conditions of wind force greater than 6 (Beaufort wind level), heavy rain or heavy snow.
- It is allowed to lift only 1 pallet of Module at a time when Module use vertical packaging, no more than 2 pallet of Module at a time when Module use horizontal packaging.

## 5.2.2 Forklift Unloading:

- During the loading and unloading process, except the forklift operator, other people should keep a safe distance to ensure the safety of personnel.
- When loading and unloading, it is necessary to be directed by special person to avoid the fork damaging the Module and forking the Module upside down. And the forklift operator must hold professional operating license.
- Forklift Control forklift transportation straight-line speed  $\leq 5\text{km/h}$ , cornering speed  $\leq 3\text{km/h}$ , avoiding panic stops and sudden starts, preventing the Module from tipping over and causing injuries to personnel and Module.
- When forklift trucks are loading Modules, the spacing of cargo insertion should be adjusted to the maximum position where the pallet can be inserted into the spacing, so that the load of two forks is balanced and should not be skewed, and the side of the Module box should be close to the blocking shelf.
- When the forklift truck is loading the Modules, avoid the sharp objects (especially the fork) touching or colliding the Module box part, to avoid damaging the internal Module.
- When using forklift to move the box with pallet to the operation area, the forklift loading and unloading process should be slow and smooth, gently lifting and placing, and the Module should be avoided from bumps and violent vibration in the transport process.
- When unloading the goods on the container, the whole pallet should be balanced as far as possible. The forklift arm should be kept relatively horizontal, and the forklift should slowly and smoothly fork out the Module from the container.
- In the process of forklift, keep a distance of 2~3 cm between the Module and the wall of the box and the neighbour Module, and then move backward slowly to avoid the friction between the Module and the wall of the box or the neighbour pallets from causing damage to the carton.
- When unloading the goods on the platform, the height of the loading and unloading platform should be the same as the height of the bottom of the wagon, if there is any height difference, it is necessary to use the steel plate pads or other jigs to assist, so as to make the goods move out of the container smoothly. When the goods are out of the container mouth, the gap between the platform and the bottom plate of the container should be avoided to cause bumps of the goods, besides, attention should be paid to the height between the top of the Module and the roof of the wagon, to avoid bumping of the Module.
- When the Module are stacked after unloading, it is recommended to keep enough distance between each pallet of Module to avoid scratching the cartons or pallets during the second transfer.



Figure 7 Please note the protection of Module and forks



Figure 8 Note the speed of the forklift truck

## 5.3 Transshipment:

- If the Module need to be transported over long distances or stored for a long period of time, please do not remove the original packaging.
- The packaged products can be transported by land, sea or air, etc. Please fix the packing box on the transport platform during transport to ensure that the packing box is firmly fixed.
- Please do not dismantle the original package when transferring at the project site. Please fix the packing box on the transport platform, make sure the packing box is fixed firmly, and prohibit the use of tricycle to transport the Module.
- If you use box trucks or other types of vehicles for transshipment, please pay attention to the use of carriages with guard rails. The height of the guard rails should not be lower than 2/3 of the height of the Module, and fastening straps should be used to fix the Module with the carriages.
- If the unpacked Module need to be transported, please put the Module on the pallet smoothly, pack the Module first, then pack the Module with the pallet, and finally pack the Module with the packing box. The form and quantity of packing can be referred to the incoming Module. It is forbidden to put the Module on the lower level when they are transported without full pallet.
- When transporting the Modules, the Modules should be placed closely between the pallets, and the gaps between the Module boxes and the vehicles, containers and the front and rear should be filled with foam to avoid collision damage to the Module.

- If the vertical package is flipped into a horizontal package by using a flipping machine, please note that the flat pallet structure should be used as the load-bearing unit of the flipped Module, and only the border surface of the Module should be used as the load-bearing surface of the flipped Module.



Figure 9 Securely fasten the assembly to the lorry



Figure 10 Do not use a tricycle to transport the Module

## 5.4 Storage:

- Please place the Module on a flat and dry ground, and keep the environment dry and ventilated.
- Keep the outer package of Module intact, keep pallets and packing cases away from moisture and direct sunlight, and take waterproof (rain) measures.
- It is forbidden to soak the pallets in water, and the storage area should be well drained on the ground first to prevent the accumulation of water after rain from causing wood rotting of the pallets or sinking of the ground, which will lead to tipping of the Module.
- If the Modules are stored in an uncontrolled environment, such as outdoor storage, they should be stacked in a single layer, double layer is strictly prohibited, and the Module should be inspected regularly.
- Long-term storage of Module in outdoor environments may result in the risk of the Module tipping over. Long-term storage of Module is recommended to be stored in standard warehouses.

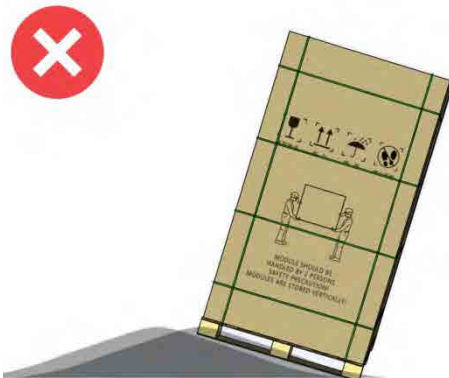

Figure 11 Do not place the Module on an uneven site



Figure 12 Please cover the Module against rain

## 5.5 Unpacking

- Before unpacking, please carefully check the mark posted on the box to confirm the Module model, power, quantity and serial number, and check whether the packing box is intact.
- Please wear protective gloves during the unpacking process to avoid scratching your hands and leaving fingerprints on the glass. At least two persons are required to unpacking.
- The working floor should keep the packing box horizontal and stable.
- Before unpacking the Module, you should place a support on the back of the Module, and the support should ensure that it will not scratch or break the Module. After unpacking, place the Module against the support.
- When unpacking outdoors, it is forbidden to work in rainy or snowy conditions. If the site is windy, special attention should be paid to safety, especially in windy conditions, it is not recommended to carry out unpacking and handling of Module, and should fix the unpacked Module properly.
- Do not allow the Module to come into contact with sharp objects to avoid damage to the Module.
- When unpacking the Module, the operator is not allowed to stand behind the leaning surface.
- When removing the packing tape of the Module, please be careful to be not scratched by the packing tape.
- After unpacking, it is prohibited to bring the electrical connectors of the Module near any unauthorized chemical substances.
- It is prohibited to lift the wires and junction boxes of the Module by lifting and pulling them. The Module can be hand-held and handled in a vertical position, and the horizontal handling of the Module may result in excessive deformation of the Module.
- The number of lay-flat stacked Module should not exceed 16 pieces.

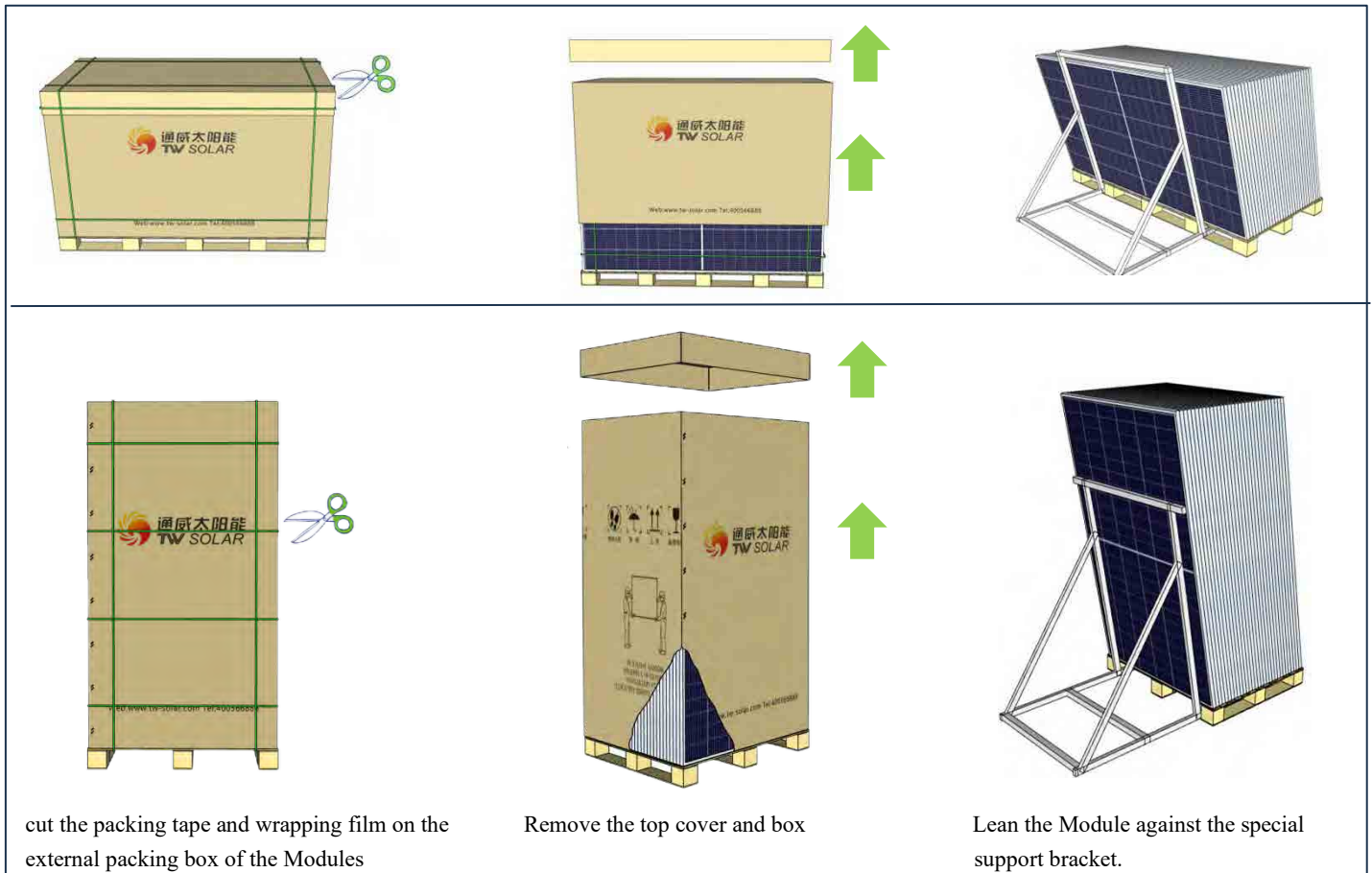

Figure 13 Schematic diagram of the unpacking procedure of the Module

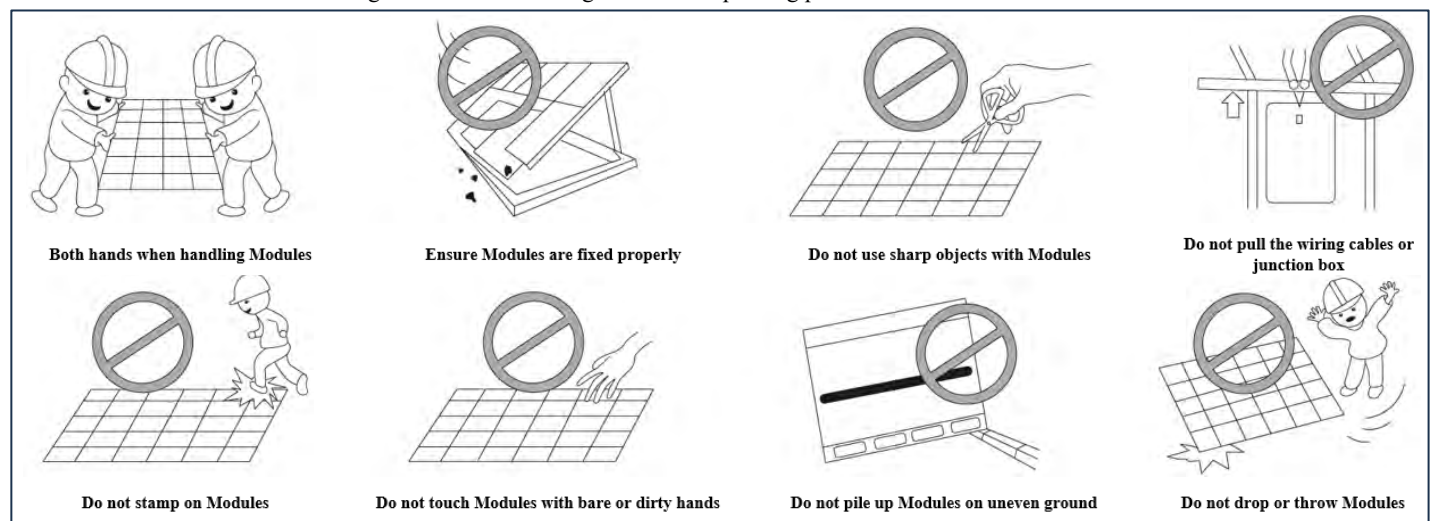

Figure 14 Description of Module handling

## 06 INSTALLATION CONDITIONS

### 6.1 Installation Environment

- Generally, the Module should be installed in the location that receives the most light throughout the year, and the location where the Module is installed should have sufficient light. If the Module is blocked or partially blocked, its power output will be reduced. Damage to the Module caused by prolonged shading is not covered by the TW warranty.
- It is recommended that the Module be installed in an operating environment with a temperature of  $-20^{\circ}\text{C}$  to  $+50^{\circ}\text{C}$ , which is the average monthly minimum and maximum temperature of the installation site. The limit operating ambient temperature of the Module is  $-40^{\circ}\text{C}$  ~  $+85^{\circ}\text{C}$ .
- The Module should be installed in a suitable place (e.g. ground, PV tracking system, roof, building facade, etc.).

- Module can be installed in freshwater environments for fishing and floating projects, as well as on land at a distance of 50-500m from the seashore, but the connectors need to be protected or dust plugs need to be added when installing the Module in areas within this distance range. Connections must be made immediately after removing the dust plugs, and other anti-corrosion measures must be taken to prevent rusting of the relevant parts.
- Module are strictly prohibited from being installed or used in environments where there are strongly corrosive substances (such as salt, salt spray, brine, active chemical vapours, acid rain, or any other substance that would corrode the Module and affect its safety or performance).
- Ensure that the wind or snow pressure to which the Module is subjected after installation does not exceed the maximum permissible load. The mechanical load that the Module can withstand is determined by the mounting method, and the calculation of the mechanical load capacity during the design of the PV system requires a professional to be responsible for carrying out the design.

## 6.2 Inclination Selection

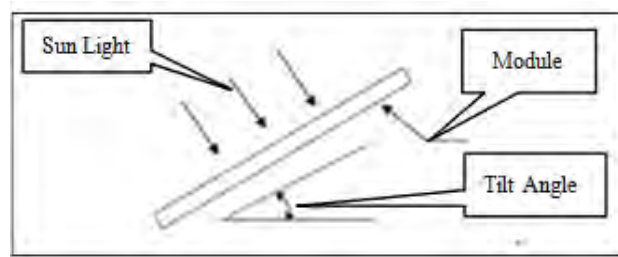

Figure 15 Schematic diagram of Module tilt angle

- Module tilt angle: the angle that the surface of the Module makes with the horizontal plane. When the Module is facing the sun, the Module will get the maximum power output. Module installed in the northern hemisphere are recommended to be placed facing south; Module installed in the southern hemisphere are recommended to be placed facing north.
- The same string of Module should be mounted at the same angle; Module mounted at different angles will receive different amounts of irradiation, which will result in lower operating efficiency of the system.
- TW recommends that the Module be installed at an angle not less than 10 degrees, so that when it rains, the dust on the surface of the Module is easily taken away by the rain, thus reducing the number of cleaning times of the Module ; at the same time, it is conducive to the flow of water on the surface of the Module, so as to avoid the long-term large amount of water leaving marks on the glass, which will in turn affect the appearance and performance of the Module.
- For detailed installation angles, please refer to the local regulatory requirements or the advice given by experienced Module installers.

## 07 MECHANICAL INSTALLATION

### 7.1 General Rules

- Ensure the Module installation method and support system sufficiently robust, so that the Modules can undertake the preset loading conditions. The support installer or supplier shall provide necessary guarantee and other related certifications. The installation support system shall pass the inspection and test by the third-party test institution with the static mechanic analysis capability, and use the local national or international standards.
- The Module shall be firmly mounted on the support, which must be made of durable, rust-resistant, UV-resistant material.
- Choose proper installation height of the photovoltaic support system, and ensure the lowest part of the Module is high enough, to avoid being shaded by plant, being damaged by the flying sand, or being covered by snow for a long time in winter.
- When the Module is installed on the roof or the building, it is necessary to ensure that the roof structure is fixed firmly and will not be damaged by heavy wind or heavy snow, and the back of the Module shall be well-ventilated to facilitate the cooling of the Module.
- Due to the thermal expansion of physical properties of materials, the Modules are asymmetric structure, which will produce a certain degree of warping deformation at different temperatures, and that does not affect the installation, use and reliability of the Modules. The minimum distance between two Modules should not be less than 10 mm.
- Ensure that the Module backside will not contact the support or architectural structure even if there is the Module surface is under the external pressure.
- It is required to observe the instruction guide and safety rules attached on the support.
- It is not allowed to drill holes in the glass surface or frame of the Module. Otherwise, the guarantee will be invalidated.
- When to install the Modules on the roof, it is necessary to guarantee the roof structure is suitable for the Module installation. And the installed Modules should not be beyond the roof zone. Additionally, the roof area where it is penetrated by Module installation shall be properly sealed to prevent the roof from water leakage.
- When the Module is installed on the supporting column, it is necessary to ensure the supporting column and Module installation structure is capable of withstanding the expected local wind.
- Any mounting structural materials used must match the Modules and any failure caused by such corrosion will void the warranty.



➤ Ensure that the drainage holes in the frame are not blocked when installing Modules.

## 7.2 Installation Method

➤ Installation with the mounting clamp of Aluminum frame Module

- ◇ When selecting the mounting clamp method, ensure that there are at least four clamps on each Module, and the clamp need to be arranged symmetrically (Figure 16). The different mounting positions of the clamps affect the maximum load capacity of the Modules (Table 1).
- ◇ The installation of the clamp shall not be in contact with the front glass of the Modules, and shall not deform the frame of the Modules. Make sure the clamp does not create shadows on the Module.
- ◇ The length of the clamp should be  $L \geq 50\text{mm}$  and the thickness  $t \geq 4\text{mm}$ . Height of side clamp is consistent with the height of module frame, make sure the clamp is firmly attached to the frame after installation (The clamp must be at least  $D \geq 10\text{mm}$  overlap with the Module frame, the clamp section can be changed to ensure reliable installation of the Module). The bolt torque of the fixed block should be determined according to the mechanical design standards of the bolts and clamps used by the customer, such as: M8:15 ~18 N·m.
- ◇ The mounting clamp should be made of aluminum alloy first, recommended 6005-T6 material,  $R_{p0.2} \geq 225\text{Mpa}$ ,  $R_m \geq 265\text{Mpa}$ . In high-load environments or when short-side overlapping installation, it is recommended to use reinforcing mounting clamp for installation of very large module, such as side reinforcing clamp or arc-shaped clamp.

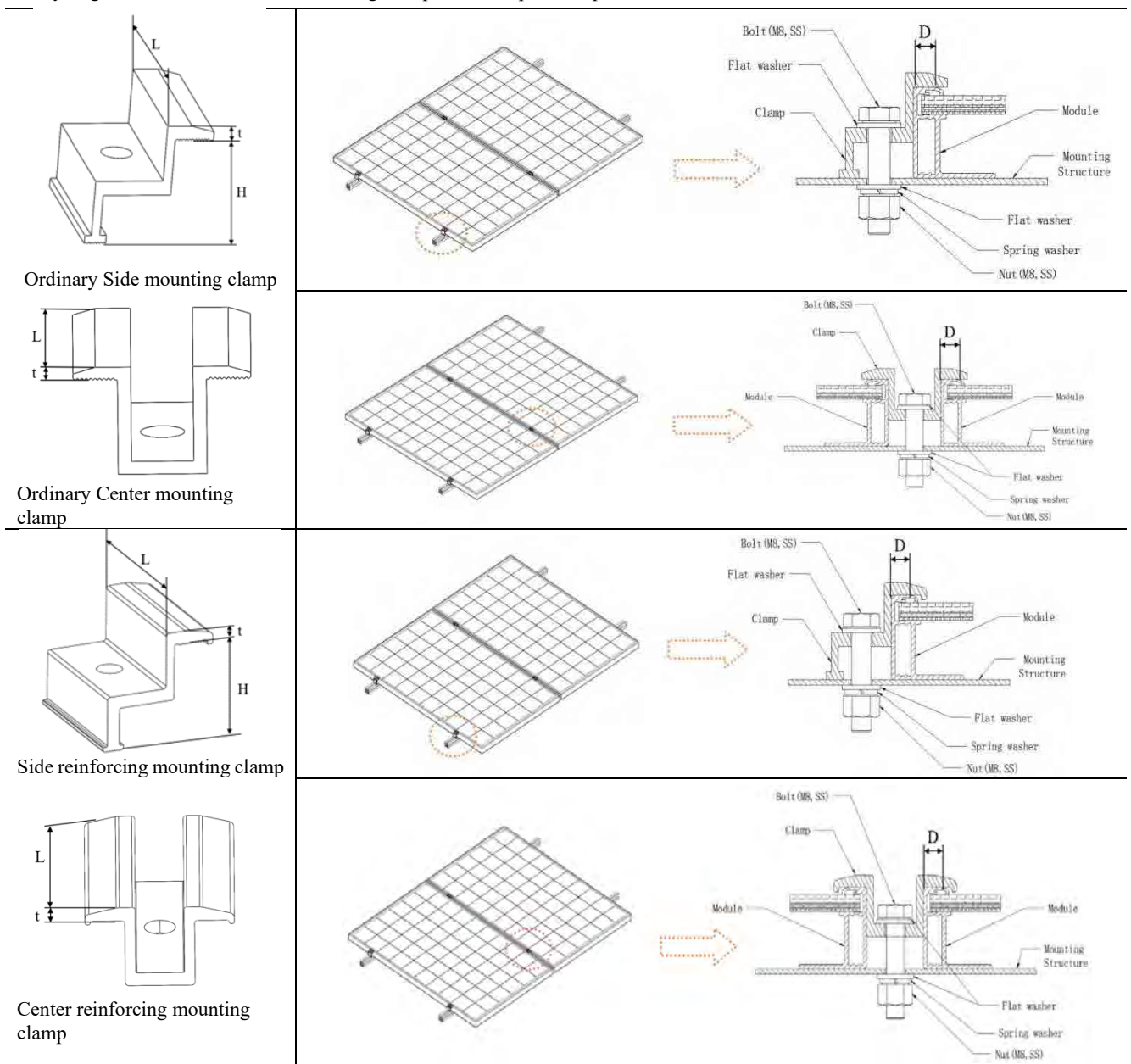

Figure 16 Mounting clamps

Table 1 Installation Method

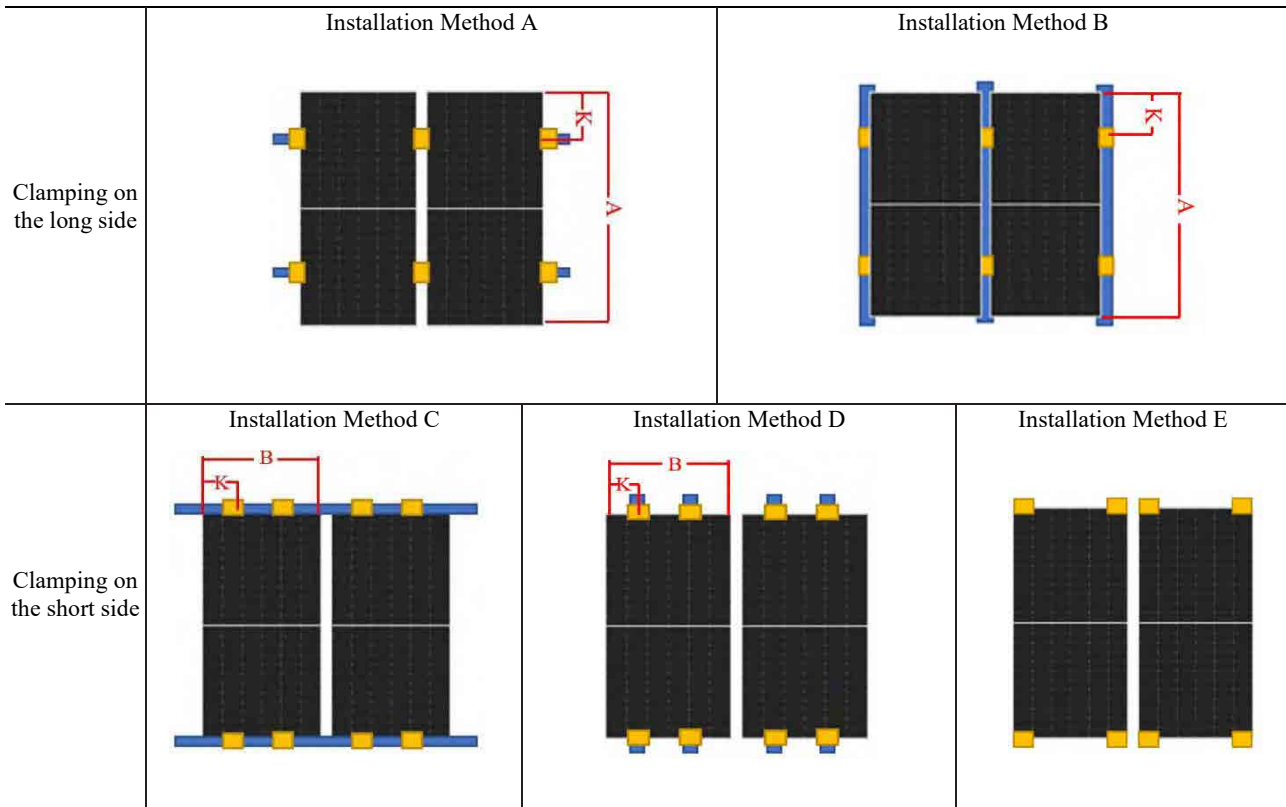

Table 2 Installation method and load capacity

Classification	Installation method		method A		method B		method C		method D	
	Modules model	Height of the frame (mm)	Mounting clamp position K (mm)	Test load: front/back, (Pa)	Mounting clamp position K (mm)	Test load: front/back, (Pa)	Mounting clamp position K (mm)	Test load: front/back, (Pa)	Mounting clamp position K (mm)	Test load: front/back, (Pa)
Monofacial Module	TWMPD-54HS TWMPD-54HB TWMND-54HS TWMND-54HB	B30	A/4±50	5400/2400	200 ~ 300	3600/2400	100 ~ 240	±1600	100 ~ 240	±1600
	TWMPD-60HS TWMND-60HS	B30		5400/2400	300 ~ 400	2400/2400	100 ~ 240	±1600	100 ~ 240	±1600
		B35		5400/2400	300 ~ 400	3600/2400	100 ~ 240	±1600	100 ~ 240	±1600
	TWMPD-66HS TWMND-66HS	B35		5400/2400	--	--	0 ~ B/4	±1200	150 ~ 240	±1600
		B30		5400/2400	--	--	--	--	--	--
	TWMPD-72HS TWMND-72HS	B35	5400/2400	--	--	0 ~ B/4	±1200	--	--	
		B35	570~630	5400/2400	--	--	--	--	--	--
	TWMPF-50HS	B35	360~420	5400/2400	--	--	--	--	--	--
	TWMPF-55HS	B35	440~540	5400/2400	--	--	--	--	--	--
	TWMPF-54HS	B35	360~430	5400/2400	--	--	--	--	--	--
	TWMPF-60HS	B35	360~420	5400/2400	360~430	3600/2400	--	--	--	--
	TWMNF-60HS	B35	A/4±50	5400/2400	360~430	3600/2400	--	--	--	--
	TWMNF-66HS	B35	A/4±50	5400/2400	-	-	--	--	--	--
TWMNH-66HS	B35	A/4±50	5400/2400	A/4±50	3600/2400	--	--	--	--	

**Table 2 Installation method and load capacity**

Classification	Installation method		method A		method B		method D		method E		
	Modules model	Height of the frame (mm)	Mounting clamp position K (mm)	Test load: front/back, (Pa)	Mounting clamp position K (mm)	Test load: front/back, (Pa)	Mounting clamp position K (mm)	Test load: front/back, (Pa)	Mounting clamp position K (mm)	Test load: front/back, (Pa)	
Bifacial Module	TWMPD-60HD TWMND-60HD	B30	A/4±50	5400/2400	A/4±50	3600/2400	--	--	--	--	
	TWMPD-66HD TWMND-66HD	B30		5400/2400		3600/2400	--	--	--	--	
	TWMPD-72HD TWMND-72HD	B30		5400/2400		3600/2400	--	--	--	--	
		B35		5400/2400		3600/2400	--	--	--	--	
	TWMPD-78HD TWMND-78HD	B30		5400/2400	--	--	--	--	--	--	
		B35		5400/2400	--	--	--	--	--	--	
	TWMPF-50HD	B35		5400/2400	--	--	--	--	--	--	
	TWMPF-55HD	B35		5400/2400	440~540	3600/2400	--	--	--	--	
	TWMPF-54HD	B35		5400/2400	--	--	--	--	--	--	
	TWMPF-60HD TWMHF-60HD	B35		5400/2400	360~420	3600/2400	--	--	--	--	
	TWMPF-66HD TWMHF-66HD	B33		500 ~ 600	5400/2400	--	--	--	--	--	--
		B35		A/4±50	5400/2400	440~540	3600/2400	--	--	--	--
	TWMNF-60HD	B33		A/4±50	5400/2400	360~420	3600/2400	--	--	--	--
	TWMNF-66HD	B33		A/4±50	5400/2400	440~540	3600/2400	--	--	--	--
	TWMNH-48HC TWMNH-48HD	B30		A/4±50	5400/2400	--	--	100 ~ 240	±1600	four angles	±1200
TWMNH-66HD		B30	A/4±50	5400/2400	A/4±50	3600/2400	--	--	--	--	

Note: Test load =  $\gamma m(\text{safety factors}) \times \text{design load}$  , during installation, avoid direct or indirect contact between the junction box and the Module support.

➤ Installation with the mounting hole of Aluminum frame Module

◇ M8 bolt kits are used for 14mm×9mm mounting holes and M6 bolt kits are used for 10mm×7mm mounting holes.

◇ When selecting the bolt mounting hole method, ensure that there are at least four bolts on each Module, and the bolts need to be arranged symmetrically (Figure 17). The different mounting positions of the bolts affect the maximum load capacity of the Module (Table 3).

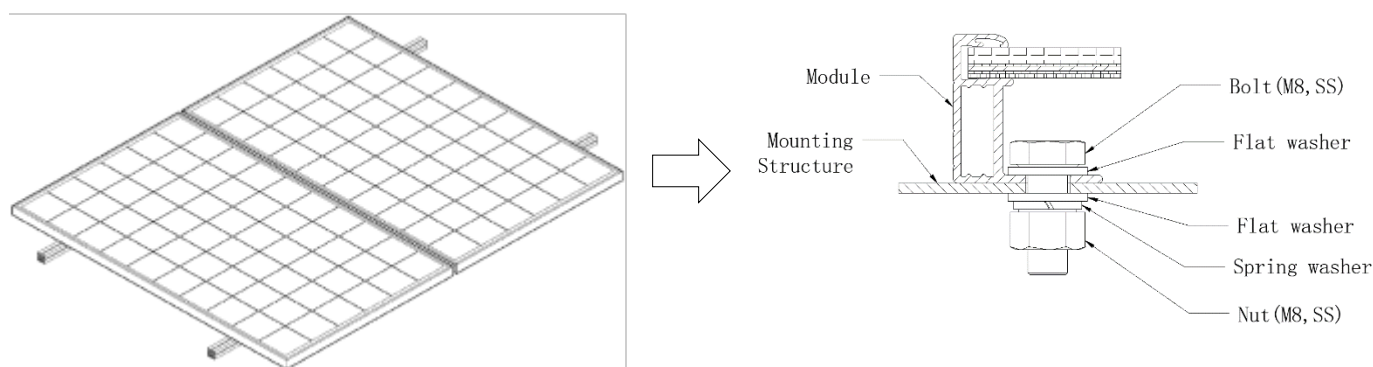

Figure 17 Bolt hole installation of Aluminum frame Module



Recommended bolt kits are as follows:

Install fasteners	M8 bolt kits	M6 bolt kits	Notes
Bolt	M8 ( full thread recommended )	M6 ( full thread recommended )	The material is hot-dip galvanized or stainless steel, and the material selection is selected according to the local environment.
Washer	2pcs, thickness $\geq$ 1.5mm and outside diameters $\geq$ 16mm	2pcs, thickness $\geq$ 1.5mm and outside diameters= 12 ~ 16mm	
Spring Washer	8mm	6mm	
Nut	M8	M6	
Bolt tightening torque range (N·m)	16~20	8~12	

Table 3 Installation Method

	Method F	Method G
Mounting on the long side		

Table 4 Mounting dimension and load capacity

Classification	Modules model	Height of the frame (mm)	The mounting clamp position M(mm)	The mounting clamp position N(mm)	Installation Method F	Installation Method G
					Test load: front/back (Pa)	Test load: front/back (Pa)
Monofacial Module	TWMPD-54HS TWMPD-54HB TWMND-54HS TWMND-54HB	B30	990	1085	5400/2400	--
	TWMPD-60HS TWMND-60HS	B30	1100	1086	5400/2400	--
			1400	1086	3600/2400	--
	TWMPD-66HS TWMND-66HS	B35	990	1085	5400/2400	--
			1400	1085	$\pm$ 2400	--
	TWMPD-72HS TWMND-72HS	B35	990	1085	$\pm$ 2400	--
			1400	1085	5400/2400	--
	TWMPD-78HS TWMND-78HS	B35	1200	1085	5400/2400	--
	TWMPF-50HS	B35	1400	1055	5400/2400	--
	TWMPF-55HS	B35	1400	1055	5400/2400	3600/2400
	TWMPF-54HS	B35	1400	1262	5400/2400	--
	TWMPF-60HS	B35	1400	1262	5400/2400	3600/2400
	TWMPF-66HS	B35	1400	1262	5400/2400	3600/2400
	TWMNF-60HS	B35	1400	1262	5400/2400	3600/2400
	TWMNF-66HS	B35	1400	1262	5400/2400	3600/2400
TWMNH-66HS	B35	790	1085	$\pm$ 2400	$\pm$ 2400	
		1400	1085	5400/2400	3600/2400	

**Table 4 Mounting dimension and load capacity**

Classification	Modules model	Height of the frame (mm)	The mounting clamp position M(mm)	The mounting clamp position N(mm)	Installation Method F	Installation Method G
					Test load: front/back (Pa)	Test load: front/back, (Pa)
Bifacial Module	TWMPD-60HD TWMND-60HD	B30	1200	1096	5400/2400	--
	1400		1096	5400/2400	--	
	TWMPD-66HD TWMND-66HD	B30	1200	1096	5400/2400	±2400
	1400		1096	5400/2400	3600/2400	
	TWMPD-72HD TWMND-72HD	B30	1200	1096	5400/2400	--
			1400	1096	5400/2400	--
		B35	1200	1096	5400/2400	±2400
			1400	1096	5400/2400	3600/2400
	TWMPD-78HD TWMND-78HD	B30	1200	1096	5400/2400	--
		B35	1200	1096	5400/2400	--
	TWMPF-50HD	B35	1400	1055	5400/2400	--
	TWMPF-55HD	B35	1400	1055	5400/2400	3600/2400
	TWMPF-54HD	B35	1400	1262	5400/2400	--
	TWMPF-60HD TWMHF-60HD	B35	1400	1262	5400/2400	3600/2400
	TWMPF-66HD TWMHF-66HD	B33	1400	1262	5400/2400	--
		B35	1400	1262	5400/2400	3600/2400
	TWMNF-60HD	B33	1400	1262	5400/2400	3600/2400
	TWMNF-66HD	B33	1400	1262	5400/2400	3600/2400
TWMNH-48HC TWMNH-48HD	B30	1100	1096	5400/2400	--	
TWMNH-66HD	B30	790	1096	±2400	±2400	
		1400	1096	5400/2400	3600/2400	

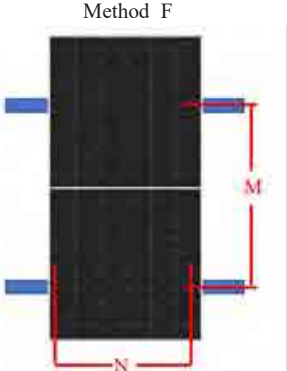
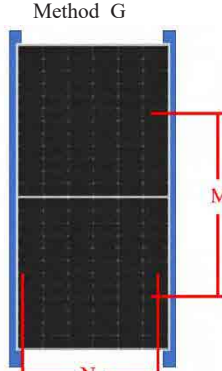
Note: Test load =  $\gamma m$ (safety factors) × design load , during installation, avoid direct or indirect contact between the junction box and the Module support.

➤ Installation of composite frame Module

◇ Installation with the mounting clamp

◇ The installation method of the composite frame Module mounting clamp is the same as that of the aluminum frame Module (Figure 18), but the special clamp of the Compound frame Module is required. Different installation positions of the clamp will affect the maximum load capacity of the Module (Table 5).

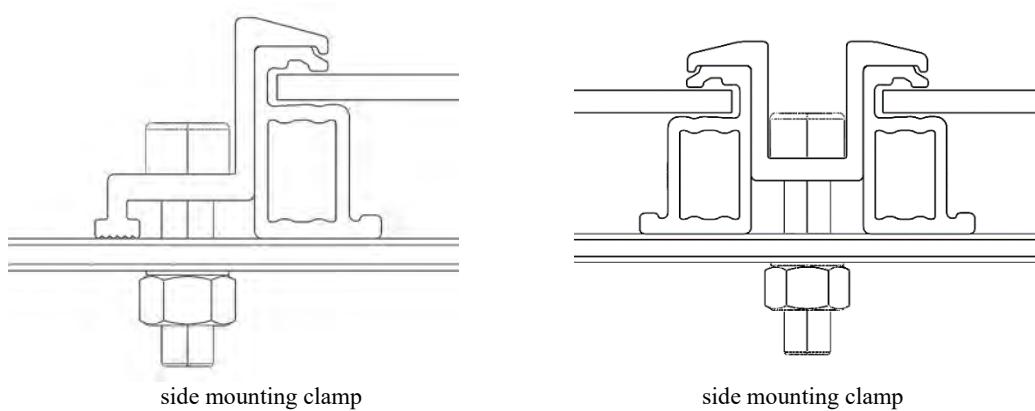

Figure 18 Mounting clamps

**Table 5 Installation method and load capacity**

Classification	Installation method		method A		method B	
	Modules model	Height of the frame (mm)	The mounting clamp position M(mm)	The mounting clamp position N(mm)	Installation Method E Test load: front/back (Pa)	Installation Method F Test load: front/back, (Pa)
Bifacial Module	TWMND-72HD	B30	A/4±50	5400/2400	A/4±50	3600/2400

Note: Test load =  $\gamma m$ (safety factors)  $\times$  design load , during installation, avoid direct or indirect contact between the junction box and the Module support

- ◇ Installation with the mounting hole
- ◇ When installing composite frame Module bolts, use special mounting holes (Figure 19) for the composite frame bolts. Ensure that each Module has at least four bolts. The different mounting positions of the bolts affect the maximum load capacity of the Module (Table 6).

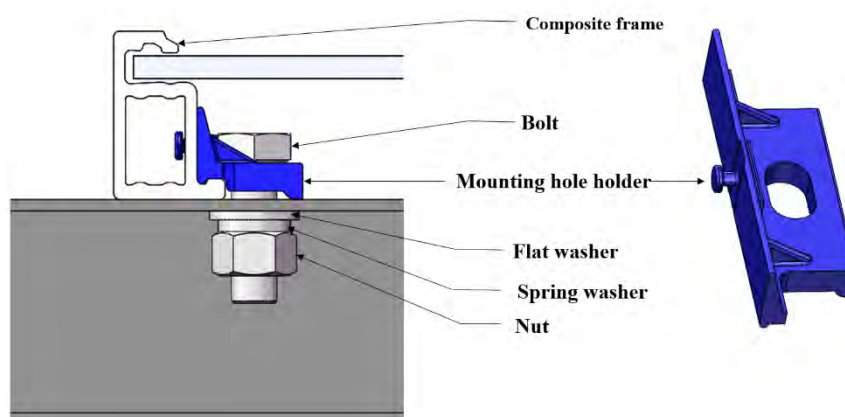

Figure 19 Bolt hole installation of composite frame Module

**Table 6 Mounting dimension and load capacity**

Classification	Modules model	Height of the frame (mm)	The mounting clamp position M(mm)	The mounting clamp position N(mm)	Installation Method F
					Test load: front/back (Pa)
Bifacial Modul	TWMND-72HD	B30	1200	1096	5400/2400
			1400	1096	5400/2400

Note: Test load =  $\gamma m$ (safety factors)  $\times$  design load , during installation, avoid direct or indirect contact between the junction box and the Module support

## 08 ELECTRICAL INSTALLATION

### 8.1 General Installation

- DC power generated by the photovoltaic system can be converted into AC power and fed into the grid. Policies on connecting renewable energy system to the grid vary from region to region. Consult senior system designer before designing the system. Generally, the system installation shall be formally approved by the local public sector.
- The electrical characteristics such as Pmax, Isc, and Voc are within certain tolerances of under STC (1000 W/m<sup>2</sup> Irradiance, a cell temperature of 25°C and an AM1.5 spectrum).
- Under normal conditions, Modules may experience emitting more power than under standard conditions. When determining the accessories of the photovoltaic power generation system, such as the rated voltage, rated current, wire capacity, fuse specifications and other parameters related to the power output of the Module, the Isc marked on the Module should be multiplied by 1.25 times.

- It is not allowed to use the Module in different models in the same solar photovoltaic system. When the Module are connected in series, the voltage of every string shall not be higher than the maximum voltage of the system (as shown in Figure 20), Please refer to the country's or local regulations for details.
- When connected in parallel, the current output is equal to the sum of each string's current (as shown in Figure 21). Fuse is necessary for each Module string. Take reference to the local regulation. Recommended maximum parallel Module configurations: Fuse rating/ (1.25\* short-circuit current). Please refer to the country's or local regulations for details.

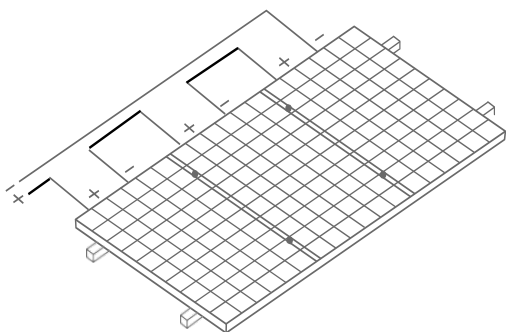

Figure 20 Connection in Series

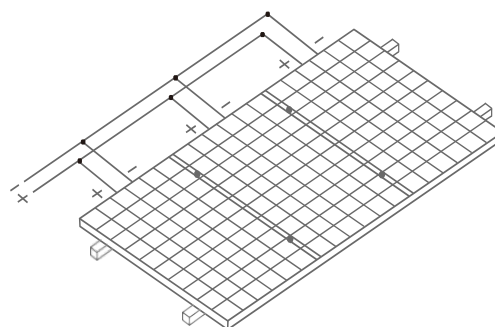

Figure 21 Connection in parallel

- The maximum allowed quantity of Module in string connection shall be calculated according to relative regulations. The open circuit voltage value under the expected lowest temperature shall not exceed the maximum system voltage value allowed by Module and other values required by DC electric parts. TONGWI Module maximum system voltage is DC1000V/DC1500V, actually system voltage is designed based on the selected Module and inverter model.
- The correction value of VOC can be calculated by the following formula.  

$$C_{voc} = 1 - \beta_{voc} \times (25 - T)$$

T: The expected lowest temperature of the installation site.  
 $\beta_{voc}$  :temperature coefficient (% /°C) .
- According to the different current of the Module, TW will classify the Module into I1, I2 and I3. When installing the Module, TW recommends that the Module with the same grade label (e.g. all I1) be installed in one string. Regarding the tail-mounted Module with different current grades, the neighbour current grades can be installed in one string.
- The connector and the junction box connector used in the order Module must remain of the same brand and the same specification model, and connectors of different brands/specifications are not allowed to plug each other.
- It is forbidden for non-professionals to open the lock nuts of the connector. Make sure that the connectors are clean, dry and fully connected (A click sound should be heard when fully connected), otherwise it may lead to electric arc sparks which will damage the connector or cause a fire.
- Completely cover the Module with an opaque material to prevent electricity from being generated during disassembling the conductors.
- Refer to local code requirements to determine the wire size, type and temperature of the system.
- The cross section of the cables and the capacity of the connectors must be selected to suit the maximum system short circuit current .The recommended section area for a single piece of Module is 4 mm<sup>2</sup>, and the recommended rated current for the connector is greater than 25A, It is necessary to select the appropriate conductor gauge for the system to reduce the voltage drop and to ensure that the conductor load capacity meets local laws and regulations and the appropriate electrical standards, otherwise the cables and connectors shall be overheated under large current. Caution: The maximal temperature of the cable is 85°C while the upper limited temperature of the connector is 105°C.
- Make sure that electrical Module such as connectors, inverters, etc. are turned off during installation of the Module. To reduce damage from lightning strikes, cable runs must be laid with the smallest possible loop area.
- In a system with two or more Module connected in series, if part of a Module is shaded while the other part is exposed to the sun, a very high reverse current will go through the cells which have been partly or entirely covered and it will cause overheat on the cells, which may damage the Module. Using bypass diodes can protect Module from this kind of risk. There are bypass diodes in junction boxes, which can reduce the effects of partial shadows. Do not privately disassemble the junction box to replace the diodes, even when the diodes are broken. This should be processed by the professionals.

## 8.2 Module Layout And Wiring

- The recommended arrangement of Modules is shown in Figure 22:

Junction Box Location Icon	Recommended Wiring Method
	<p>Vertical mounting: standard line length</p>  <p>Note: Extension cables are required at the header of the double row and at one end of the single row.</p>
	<p>Horizontal mounting:</p> <p>182 version of the Module: 54 version of the Module single wire length should be <math>\geq 1.2\text{m}</math>; 60 version of the Module single wire length should be <math>\geq 1.2\text{m}</math>, 72 version of the Module single wire length should be <math>\geq 1.4\text{m}</math>, 78 version of the Module single wire length should be <math>\geq 1.5\text{m}</math>;  210 version of the Module: 54 version of the Module single wire length should be <math>\geq 1.2\text{m}</math>; 60 version of the Module single line length needs to be <math>\geq 1.4\text{m}</math>, 66 version of the Module single line length needs to be <math>\geq 1.4\text{m}</math>.  182*210 210 version of the Module: 48 version of the Module single wire length should be <math>\geq 1.2\text{m}</math>; 66 version of the Module single wire length should be <math>\geq 1.4\text{m}</math>.</p> 

Figure 22 Common ways of arranging Module

## 8.3 Cables And Connectors

- To ensure proper system operation, when connecting Module or connecting loads (e.g., inverters, batteries, etc.), observations should be made to ensure that the cables are connected with the correct polarity. If the Module are not connected correctly, the bypass diode may be damaged.
- When the cable is fixed to the bracket, it is necessary to avoid mechanical damage to the cable or the Module and not to press the cable hard. The minimum bending radius of the Module's cable is 38.4mm. Damage to the cable due to excessive bending or the use of an unsuitable cable management system will not be covered by the warranty.
- Before connecting, please use diagonal pliers to cut the cable ties, and be careful not to scratch the cables and the backplane. Before the commissioning of the power station, it is necessary to carry out an electrical inspection of the Module and strings to confirm that the polarity of the strings is correct and that their open-circuit voltage meets the requirements of the acceptance specification.
- Please keep the connector dry and clean, and make sure the connector's nut is tightened before connection. Do not connect the connector if it is wet, dirty or otherwise.
- Keep the connector out of direct sunlight and rain, and away from areas where water collects. Avoid dropping the connector on the ground or on the roof.
- In connection and use environment, connectors are prohibited from contacting contact with organic solvents and other corrosive materials, such as: alcohol, gasoline, pesticides, herbicides, etc., TW is not responsible for connector cracking caused by the above reasons.

## 8.4 Grounding

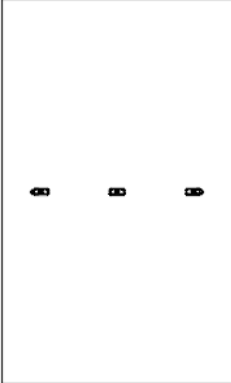
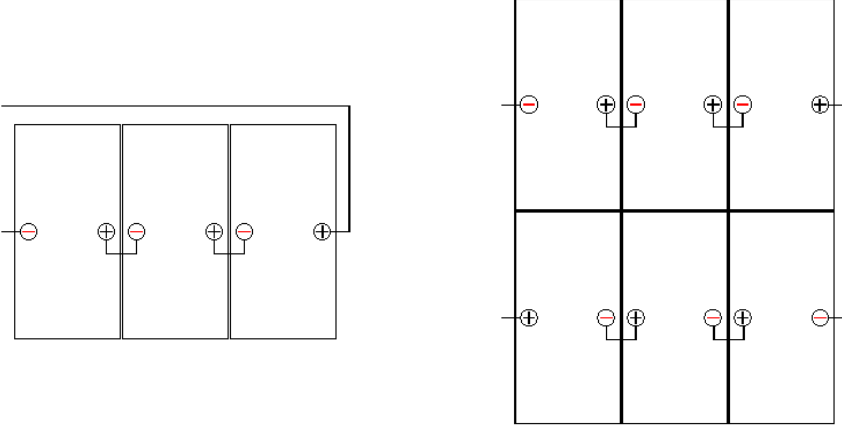
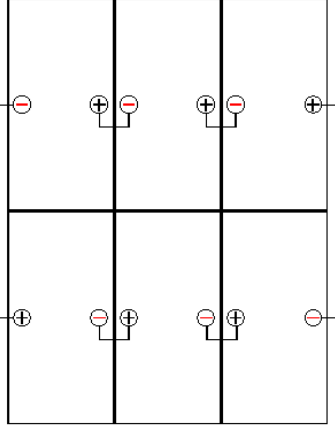
- All Module frames and mounting brackets must be properly grounded in accordance with the relevant electrical design and construction codes, rules, regulations, and other special grounding requirements for the location where the Module is installed.
- Proper grounding is achieved by continuously connecting the Module frame and all metal components together using a suitable

grounding conductor. The grounding conductor or earth wire may be a material such as a copper alloy or other material that complies with the electrical conductors specified within the applicable electrical design and construction codes, rules, and regulations for the installation site. The grounding conductor must be reliably grounded through a suitable grounding electrode.

- The frame has been pre-drilled and marked with a grounding symbol. These holes are for grounding only and cannot be used for mounting the Module. Do not drill any additional grounding holes in the frame of the Module or the warranty of the Module will be voided (unused holes in the frame for mounting the Module can also be used for grounding).
- When grounding, the grounding device must be in full contact with the inside of the aluminum alloy, penetrating the oxide film on the surface of the frame.
- Grounding between Module must be verified by a qualified electrician and the grounding fixture must be manufactured by a qualified electrical manufacturer. Use 12 AWVG size copper core wire for the grounding fixture, and the copper wire must not be crushed during installation.
- Installation with grounding wire and bolt: The grounding bolt is recommended to be made of stainless steel and used in the designated grounding hole. Insert the stainless steel bolt through the spring washer, cup washer, flat washer, star washer, then through the grounding hole in the frame, the flat washer, the spring washer, and finally tighten it with the nut, as shown in figure 23.
- Installation using the terminal nose with bolts: first, strip the grounding cable head to the appropriate length, take care not to damage the metal core during the stripping process, and insert the stripped grounding cable head into the socket of the terminal nose, and then tighten the fastening screws, and then use the stainless steel bolts and connectors to connect the terminal nose to the aluminum frame. The installation schematic diagram is shown in figure 24.

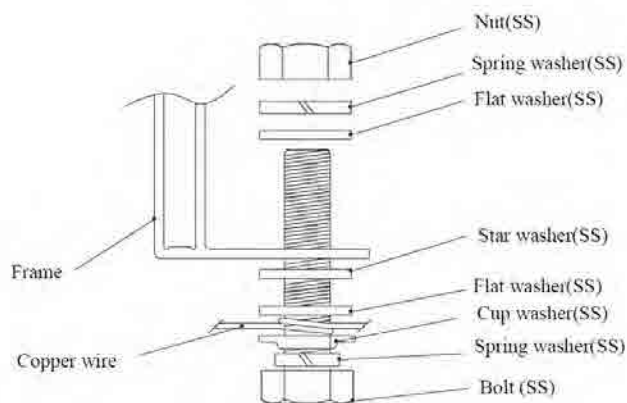

Figure 23 Ground Wire Mating Bolt Installation Schematic

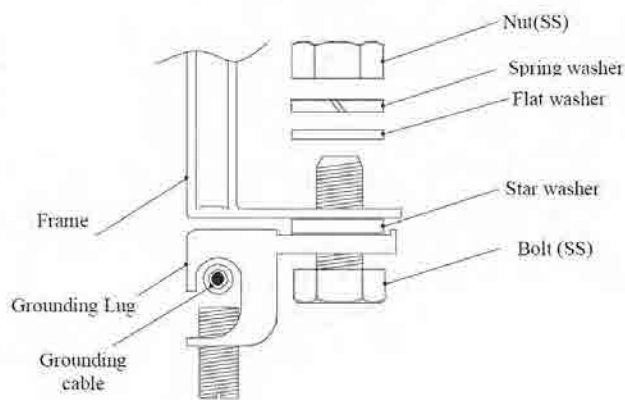

Figure 23 Ground Wire Mating Bolt Installation Schematic

## 09 MODULE MAINTENANCE

- To ensure safe operation and optimum performance of the Module, they must be inspected and maintained on a regular basis.

### 9.1 Module Appearance Inspection

- Preventive examinations are recommended every 6 months, focusing on observing the following items:
  - ◇ Check if the Module surface is obstructed by obstacles or foreign objects.
  - ◇ Check whether the Module glass is broken.
  - ◇ Check whether there is any change in the color of the Module (the Module uses a reflection-reducing film technology, so it is normal to observe the Module from different angles and find that there is a difference in color).
  - ◇ Check the Module backsheet whether there is high temperature, backsheet raised, burn through the traces and so on.
  - ◇ Check whether the cell busbar is corroded, whether encapsulation materials of the Module have delamination, bubbles, etc.
  - ◇ Check the tightness of the bolts and the electrical connections at the connection points between the Module and the supporting rail.

### 9.2 Inspection Of Connector And Cable

- Preventive examinations are recommended every 6 months, focusing on observing the following items:
  - ◇ Check Junction box adhesive for cracks or gaps.
  - ◇ Check the connector interface sealing and whether there is loose connection, melt deformation, aging or corrode.
  - ◇ Check that the cable connections are secure and that the Module are properly grounded.

- ◇ When Module is found to be defective, consult a qualified service technician. If servicing is required, it should be serviced by a qualified service technician.
- ◇ Module exposure generates high voltages in the sun, so cover the Module with opaque material when servicing Module to prevent electrical shock.
- ◇ Note:
  1. If found in the maintenance of any problems, feedback to the professional service personnel for confirmation.
  2. If using maintenance and repair measures not included in this manual, consult your local dealer for professional support.

## 9.3 Module Cleaning

- The accumulation of foreign objects or obstacles on the Module surface over time can reduce the Module's power output, so, it is necessary to regularly clean the surface of the Modules glass. Normally, rainfall is sufficient to keep the Module glass clean, it is still recommended that the Module should be cleaned at least once a year, and more frequently in dusty environments. The following should be noted when cleaning the Module:
    - ◇ Modules cleaning should be performed during the early morning or evening when the sunlight is not too strong, and the temperature of Modules is relatively low. Before cleaning, please ensure that the circuit is disconnected.
    - ◇ The cleaners should wear insulation gloves and other protective gear. It is strictly prohibited to clean the back panel, cables, and connectors of the Modules with water.
    - ◇ Glass surfaces of the Modules can be cleaned with a dry or damp soft sponge or cloth. For stubborn dirt, you may use a neutral, non-abrasive cleaning agent. It is strictly prohibited to use cleaning agents containing acid, alkali when cleaning.
    - ◇ If using high-pressure water for washing, the maximum water pressure should not exceed 4 MPa. Soft water is recommended, with PH 6-8;
    - ◇ Avoid applying localized pressure on the Modules during cleaning, as this may cause deformation of the Modules glass, damage to solar cells, and a reduction in the Modules' lifespan.
    - ◇ Timely removal of snow from the Modules is important to prevent long-term accumulation and the damage caused by snow melting and freezing. However, refrain from cleaning the Modules in extreme weather conditions.
    - ◇ Do not pierce the back-sheet when cleaning the back of the Module.
    - ◇ Do not attempt to clean Module with features such as broken glass or the presence of exposed wires, which may be subject to electrical shock.
- 



**Warning: Shut down the system before any electric repair.**

**Improper maintenance may cause electric shock or fire**





**客户服务热线:** 4000566888

**Customer Service Number:** 4000566888

**售后服务邮箱:** [twcustomerservice01@tongwei.com](mailto:twcustomerservice01@tongwei.com)

**After-sales E-mail:** [twcustomerservice01@tongwei.com](mailto:twcustomerservice01@tongwei.com)